



WHEATON PARK DISTRICT GIRLS SOFTBALL

AAA-League (12U)

The intent of the “AAA” League shall be to continue to teach how to play, appreciate and respect the game of organized softball in an enjoyable environment of teamwork, healthy competition, and good sportsmanship. This league is open to anyone in 5th or 6th grade at the time of registration.

Leagues/Teams from nearby communities may participate in this league. If these participating leagues/teams are organized by age instead of grade, the coinciding league must be age 12U (12 and under).

USSSA’s Official Fastpitch Playing Rules and By-Laws, are the Official Rules of Play (available at https://usssa.com/docs/Fastpitch/Fastpitch_Rules.pdf) unless otherwise stated in these 2024 AAA League Supplementary Rules and the WPD Youth Baseball / Softball “Policies and Procedures”.

2024 SUPPLEMENTARY RULES

1. LEAGUE-SPECIFIC GENERAL INFORMATION

- A. One or more umpires will be provided for all League games. If an umpire is not present, managers must mutually agree on a potential substitute(s). The substitute umpire can call the game from behind the pitcher if no safety equipment is available.
- B. Bases will be 60 feet apart. The pitching rubber will be 37½ feet from home plate (from the rear point of home plate to the front of the pitching rubber).
- C. Game duration will be 7 innings with the following exception: A new inning may not start any later than 1 hour 45 minutes past the scheduled start time.

NOTE: *A new inning begins immediately after the last out of the preceding inning.*

- 1. Games played on an outside community’s field may have a time limit based on that community’s field usage agreements with their governing Park District. Those communities and their time limits will be outlined by the league VP and conveyed to the managers at the league managers meeting.
- 2. Any weekday game (Mon – Fri) with a night game immediately following, will begin at 5:45PM. A new inning may not start any later than 7:45PM.
- 3. During the school year, night games may be played on Friday, Saturday, or any night that is followed by an official school holiday the next day.

4. A game is official after 5 or more innings or if the home team is in the lead at the end of 4½ innings. The score of “official games” that are stopped prior to the completion of the 7th inning will revert to the score of the last complete inning unless the home team is leading at the time play is stopped. If play is stopped before the game is official, the game is “Suspended” and will be played from the point where play was stopped at another date scheduled in cooperation with the League Vice President.
 5. A tie game will be declared an official game if the score is even and the game is called due to darkness, rain or time limit, provided at least (5) complete innings have been played.
 6. Bad weather or field condition may result in the postponement or cancellation of a game. Prior to the scheduled game start time, if no league official or umpire is present, the Home Team Manager will make the final decision to play, postpone or cancel the game due to field condition or weather. **See the Wheaton Park District’s “Storm Policy” in the Wheaton Park District Youth Baseball/Softball Policies and Procedures and “Game Cancellation Procedure” in your Managers Packet.**
 7. In the event of a Rainout or a non-complete game (see section 1, C, 3) called for whatever reason, both teams must agree on a reschedule date that is as close to the original game as possible. The objective is to save dates for games that may rain out late in the season. The Home Team Manager must notify the League Vice President within 48 hours with the agreed upon reschedule date. Failure to notify the League Vice President within 48 hours will result in a reschedule date assigned by the League Vice President. Only weather related events will cause the rescheduled game to be canceled and rescheduled.
- D. School, Scout, Church, Family Events, Sickness or Injuries may make it difficult to field a full team. In these situations, managers may call up players from the AA League. However, in all cases, a minimum of 7 roster players must be present or the game will be declared a forfeit. To avoid a forfeit, a team may reschedule the game, providing the Manager notify the League Vice President and the opposing Manager no less than 48 hours prior to game start time. Follow the **“Game Cancellation Procedure”** in your Manager’s Packet. In the case of a forfeit, teams may decide to swap roster players to play a practice game.

The call-up rules are as follows:

1. Call-ups cannot pitch.
2. Call-ups cannot play more innings than any roster player.
3. Call-ups must bat at the bottom of the order.
4. Call-up players can be used by the same team only 3 times per year.
5. A maximum of 3 call-ups may be used in any game and any team using call-ups cannot exceed 10 players

NOTE: At the beginning of the season, a “call up player list” will be developed by the Vice President of the AA-League who will provide 3 or more players per team capable of playing in the AAA-League as substitute players.

- E. Free substitution is permitted on defense, but such substitution will take place only between innings. During an inning, a player cannot be brought off the bench to play except if an injury occurs. Players may change positions during an inning **only** when a pitching change occurs. No other position changes are permitted during an inning.

- F. All attending players will play defense and play the maximum number of innings possible given the number of players present. This means that no player will sit out 2 innings unless all players have sat out 1 inning, and no one will sit 3 innings unless all players have sat out 2 innings. In addition, a player will not sit out 2 consecutive innings.
- G. During a complete 7 inning game, every player must play at least two innings in a position other than the three outfield positions. **The penalty for failure to comply is the decision of the League VP, including game forfeit.** Managers must compile a complete line up (including positions) for every inning and have it available for league officials to review if needed. In addition, managers are required to exchange their complete line ups with the opposing team's manager prior to the start of each game. *While enforcement of this rule is difficult, managers feeling that there has been an infraction of this rule must file a protest with the umpire immediately following the last out. At that point both managers will relinquish their line ups to the umpire who will forward them to league officials. Game protest protocols will then be followed (see WPDYBS policies and procedures).*
- NOTE:** In a complete game where only 6 innings have been played, every player must have played at least one inning in a position other than the three outfield positions.
- INTENT:** *It is mandatory that Managers rotate all defensive players.*
- H. Managers and coaches will not question judgment calls made by the umpire, such as fair or foul, safe or out, etc. Managers may approach the umpire if an interpretation of the rules is in question. The manager must ask for a "time-out" after the play is completed. Both managers, and only the managers, will be present during the conference. The discussion will be conducted in a calm and respectful manner. The decision of the umpire is final.
- I. Team standings in this league will be determined using the following criteria: "Winning Percentage" will determine league standings. Specified Tie-Breaker criterion in sequential order will be: Head-To-Head Comparison, Total Runs Allowed, Total Runs Scored and Coin Flip. Standings will determine the number of players each team will send to the All-Star Game and for Team Seeding in the Modified Double Elimination Tournament. In the event teams have not played an equal amount of games, the League Vice President shall have the discretion to determine the basis for calculating standings criteria.

2. LEAGUE-SPECIFIC OFFENSE RULES`

- A. During the first 6 innings of a game teams will be limited to 5 runs per inning unless the offensive team is behind by more than 5 runs. In this case, the offensive team can score enough runs to tie the score.
- During the 7th or any extra inning of play, a half-inning will consist of 3 outs with no limitation on the number of runs scored. However, if the visiting team takes a 20-run lead their half inning will end, the home team will take their at bat and can only score enough runs to tie the game.
- B. Base stealing is allowed for all bases, including home plate. However, base runners must remain in contact with the base until the ball crosses the plate. If a runner leaves a base too soon, the ball will become dead, a "no pitch" declared and the runner called out. All other runners will return to the base they were at when the infraction occurred.

- C. **All base runners must attempt to avoid a collision with a fielder in possession of the ball, or about to field a batted ball.** Any runner who remains on her feet and crashes into a fielder making the play in these situations, whether intentional or not, will be called out for interference. Furthermore, if the act is determined to be flagrant or malicious, the offender will be restricted to the bench for the duration of the game. Runners have three options to avoid a collision: 1) slide into the base they are going to, 2) step around a fielder, or 3) pull up and allow themselves to be tagged.

NOTE: *A collision that occurs when an errant throw draws a defensive player into the path of the runner is considered incidental contact. It is not interference, and no penalty will be imposed to either the defensive or offensive player.*

Conversely, a fielder may not impede the progress of a runner who is legally running bases while not in possession of the ball, not about to field a batted ball or not about to receive a thrown ball. Obstruction will be called in these situations, and the appropriate ruling will be made.

- D. Bunting is allowed.

- E. Fake Bunt then Pull Back and Swing Away at the same pitch is **NOT ALLOWED**.
(other known names: Fake/Slash Bunt, Power Slash Bunt, Butcher Boy Swing)

A batter is not allowed to show bunt, then pull back the bat, and swing away. Once a batter shows bunt, they can only continue to attempt a bunt or pull the bat back and take the pitch. The penalty for doing this, whether swing and miss, hit a fair or foul ball, is an automatic dead ball, the batter is out and any runners return to base they previously occupied.

NOTE: *The Batter can show bunt, pull back and then attempt or complete a bunt.*

INTENT: **Safety Issue!** *The act of a Fake Bunt then attempting or completing a full or partial swing draws the infield players toward the batter to a point where player safety becomes a concern and the potential for serious injury exists. The Wheaton Park District Youth Baseball/Softball Board of Control maintains a "Zero-Tolerance" policy regarding acts that potentially effect player safety.*

- F. The infield fly rule **will not** apply.

- G. The dropped third strike rule **will** apply (*with the following restrictions*):

RESTRICTION-1: *The batter/runner may only advance to 1st base.*

RESTRICTION-2: *Any base runners already on base during the at bat may also advance only 1 base.*

EXCEPTION: *If the defense makes a play on a base runner other than the batter, there will be no restrictions (unless that play is a force play with 2 outs).*

NOTE: In the event of an errant throw at 1st base (or a force play with 2 outs), all play will cease and a "dead ball" will be declared. Any runners attempting to advance will be sent back to the base they were allowed without penalty.

- H. **RUN RULE:** A game will end any time after 3½ or 4 innings when a team is 15 or more runs behind and has completed its turn at bat.

OPTION: *Upon team manager's agreement, the game will continue as a "practice game" according to the time rules in 1. C.*

- I. No more than two time-outs will be allowed by any Manager or Coach while on offense to confer with a batter or batter-runner per inning. A third attempt to “**stop**” or “**delay**” play in the same inning, while on offense will be denied.
- J. A player unable to finish a game may miss a scheduled turn at bat without penalty provided it is reported to the umpire prior to the scheduled at bat. Failure to report could result in a “batting out of order” appeal by the defensive team. Players injured during a scheduled at bat will be replaced by the last recorded out. That player will resume the existing count and finish the at bat and/or become the base runner. The original batting order (less the injured player) will resume for the remainder of the game
- K. If the catcher that is scheduled to catch in the next inning is on base with 2 outs, it is mandatory to provide a pinch runner so the catcher can prepare for the next inning. A pinch runner may also be used for the pitcher scheduled to pitch in the next inning, but it is not mandatory. The pinch runner(s) will be the last recorded out(s) of the inning.
- L. Late arriving players may be added to the lineup only prior to the completion of the first inning. That player(s) must bat last and will be considered as having played the full game for the purposes of player rotation and bench sitting rules (Rules 1.F. and 1.G.).

3. LEAGUE-SPECIFIC DEFENSE RULES

- A. A team must field a minimum of 8 players.
- B. A pitcher is limited to 4 innings per game, regardless of the game length, and the innings need not be consecutive. A player has pitched a complete inning as soon as she throws 1 pitch during an inning. If more than 1 pitcher is used in a single inning, each pitcher will be considered to have pitched that complete inning. A pitcher that is removed and re-enters during the same inning will only be charge 1 inning.
 - i. **NOTE:** In the event of extra innings, all pitchers are allowed to pitch one additional inning.
- C. A time out called by a manager or coach for a second conference with a pitcher in same inning automatically requires a change of pitchers. Replacement pitcher must be one of the players already in the field, not from the bench (refer to 1. E.).
- D. A pitcher who hits 3 batters with pitched balls in the same inning must be removed from pitching for the balance of that inning. She may return to pitch in subsequent innings as long as she is within the 4 inning limit described in Rule 3. B.
- E. All pitchers must comply with USSSA pitching regulations. The windmill or slingshot pitching style may be used in addition to the basic underhand delivery.
- F. Intentional walks are not allowed.



WHEATON PARK DISTRICT GIRLS SOFTBALL

AAA-League (12U)

2022 MODIFIED DOUBLE ELIMINATION TOURNAMENT RULES

USSSA's Official Fastpitch Playing Rules and By-Laws, are the Official Rules of Play (available at https://usssa.com/docs/Fastpitch/Fastpitch_Rules.pdf) unless otherwise stated in these 2022 AAA League Supplementary Rules and the WPD Youth Baseball / Softball "Policies and Procedures" and these 2022 Modified Double Elimination Tournament Rules".

1. The League Vice President will be the Tournament Director, prepare the tournament calendar, game schedule and tournament bracket.
2. Team seeding will be determined by final team standings of the leagues regular season. See section 1. I. of the "League Supplementary Rules".
3. Highest seeded team between teams playing will be the home team throughout the tournament with the exception of the "Championship" game. The home team will be the team that came through the "winners" bracket. If there is a consolation game, the highest seeded team will be the home team.
4. For all games played, game duration will be 7 innings with a "no new inning after 2 hours" time limit will apply.
5. Game start time during weeknights (Monday – Friday) will be 6:00 PM for all games played on lighted fields. Games played on non-lighted fields will start at 5:45 PM. The Tournament Director (League V. P.) reserves the right to change the tournament format, field assignments and schedule due to field conditions, foul weather, restrictions, etc.
6. Game start time is forfeit time unless teams are held up by a late running game.
7. There will be a maximum of five warm-up pitches allowed between innings. A mandatory pinch runner will be used when scheduled catcher is on base with two outs. The catcher must be ready by the third out (unless they were the last batter). A pinch runner may also be used for the pitcher scheduled to pitch in the next inning, but it is not mandatory. The substitute runner(s) will be the last recorded out(s) of the inning.
8. Umpires will keep the games moving to help get the 7 innings in, please cooperate & keep the players moving. Players should hustle on and off the field and the battery should be ready.
9. **INTERNATIONAL TIE BREAKER:** This rule will be used in tie games, in extra-inning games, or after the time limit expires, whichever comes first. At the top and bottom of each extra inning, each team starts with a runner on second base. The base runner will be the last scheduled batter of the inning (if every player were to bat once). Game continues playing regular rules until the tie is broken. In the event a game goes to ITB, all eligible players will be allowed to pitch one additional inning.

10. **CHAMPIONSHIP GAME:** The Championship Game will be 7 innings with no time limit. If the game is tied after 7 innings, the game will continue in extra innings until the tie is broken. The international tie breaker rule will not be used in the Championship game. If the game goes to extra innings all eligible players will be allowed to pitch one more inning.



**Wheaton Park District
Youth Baseball / Softball Board of Control**

FAST PITCH SOFTBALL

AAA-LEAGUE (12U)

Field Dimensions, Marking Lines and Distances

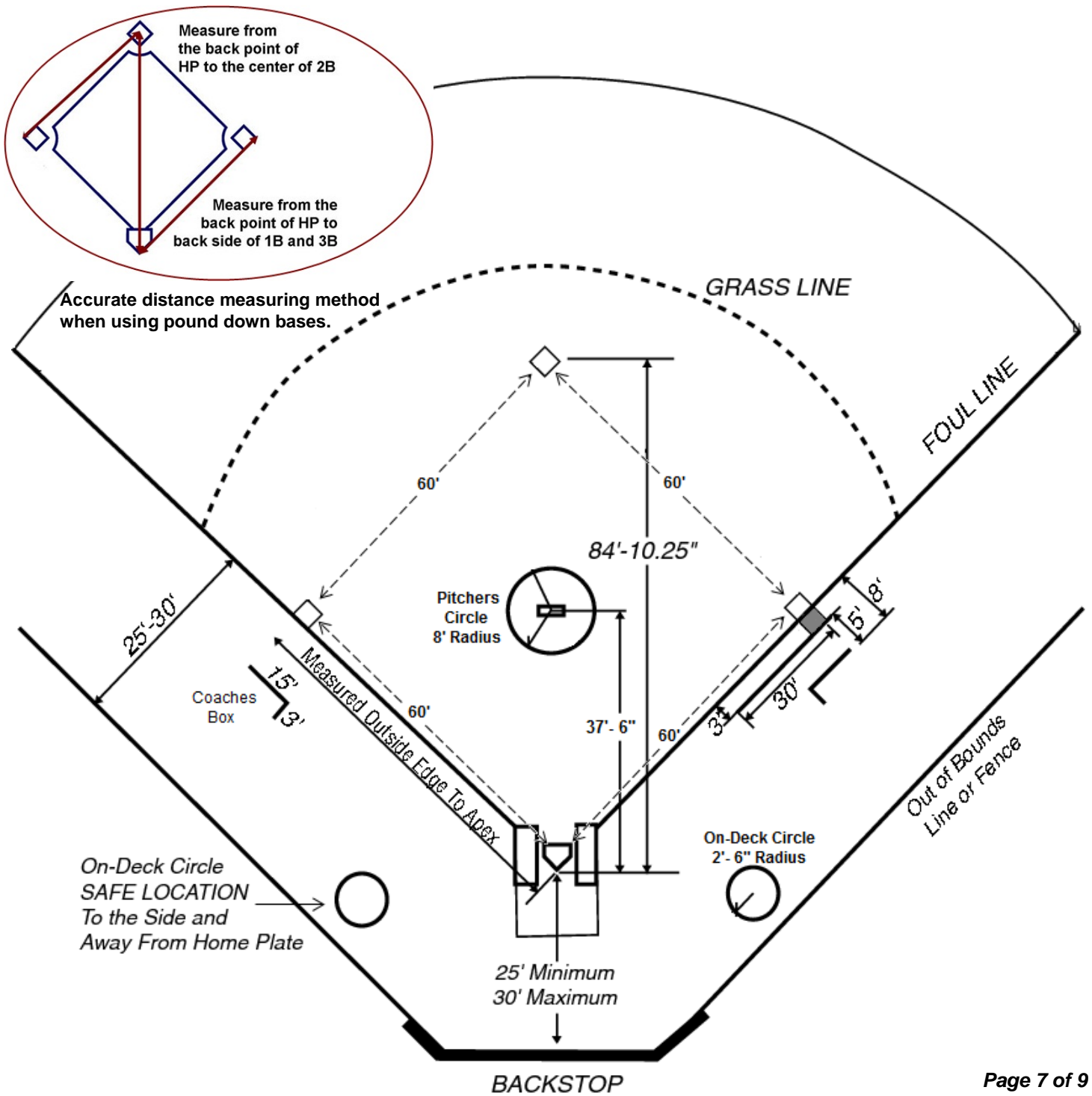



Wheaton Park District Youth Baseball / Softball Board of Control

FAST PITCH SOFTBAL

AAA-LEAGUE (12U) Specific Field Area Detail

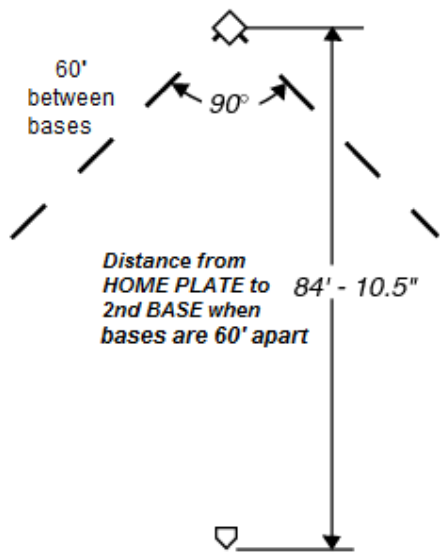

SECOND BASE AREA DETAIL

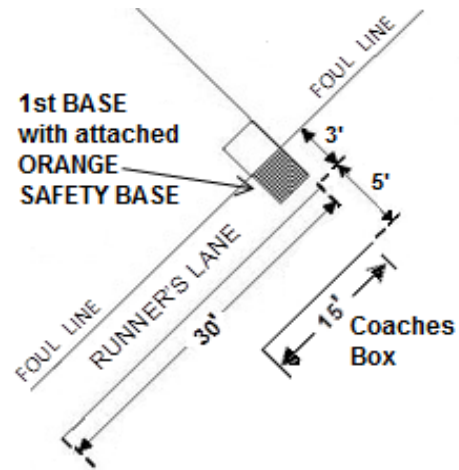

FIRST BASE AREA DETAIL

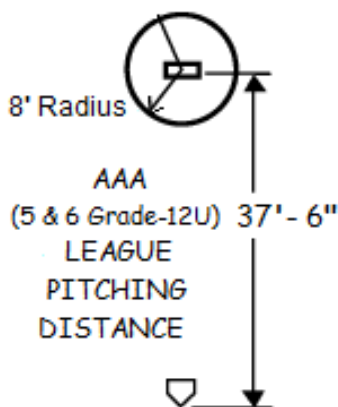

CIRCLE AREA DETAIL & PITCHING DISTANCE

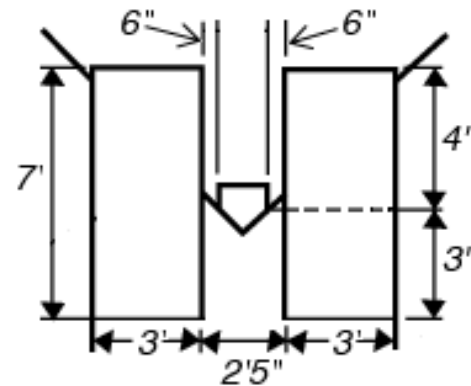

HOME PLATE & BATTERS BOX AREA DETAIL



Wheaton Park District Youth Baseball / Softball Board of Control

FAST PITCH SOFTBALL

Rules for Orange Safety Bases

Softball & Baseball Rules for Orange Safety Bases

In youth softball and baseball, one integral step toward safety is the use of the safety base at first. This innovation leads to fewer collisions along the base line and less risk of injury. The first baseman makes the play by standing on the original base while the runner will run over the orange safety base.

Description

The safety base is built as two standard bases in one. A standard baseball or softball base measures 15 inches by 15 inches. A safety base measures 15 inches by 30 inches. Half the base is the standard white color and the other half is fluorescent orange.

Placement

The safety base is used only at first base and is placed directly on the first base foul line. The white portion of the safety base is placed inside of the foul line - in fair territory, the orange half is placed in foul territory.

Rules

The safety base is designed to prevent collisions and other contact incidents at first base. The first baseman and other defensive players are only allowed to touch the white portion of the safety base during play. If a defensive player's foot touches the orange portion of the base, the umpire may call interference and award the runner a free base. This is an umpire's judgment call.

The orange base can be used by the fielder if the throw is coming from foul territory. In this case the runner would use the white base.

On offense, the batter runner must use the orange portion of the base during infield or close plays. Because a batter runner is allowed to run through first base, he/she must run straight through the orange half, remaining in foul territory. If he/she touches the white half on a play at first, the defensive team may appeal the play. If the umpire noticed the runner's foot placement, he/she will be called out. If there is no play to be made at first base, such as on a hit that will result in a double or better, the batter runner may touch the white half of the base while making the turn toward second. Batted balls that hit the white portion of the base are fair, while balls that hit the orange half are foul.

Summary

The use of the safety base not only limits potential dangerous collisions at first but also incidences of ankle injuries caused by one player stepping on another's ankle as they both stretch for the same base. When the first baseman has his/her foot on the white, and the runner sprints over the base, there's a chance of the runner rolling his/her ankle by stepping on the first baseman's foot.