



WHEATON PARK DISTRICT GIRLS SOFTBALL

A-League (8U)

The **A-League (Modified Player Pitch)** has been established as a transitional step between the *Instructional* and “AA” Leagues, preparing players for the transition from “coach” pitch to “player” pitch. The league is limited to those players currently in the 2nd grade at the start of the season.

This league, like *Instructional*, is a continuation of introducing players to the fundamentals of organized Softball. The intent of Wheaton Park District Youth Softball is to teach players the rules of the game, develop skills, provide an opportunity for fun, and teach teamwork and good sportsmanship.

Leagues/Teams from nearby communities may participate in this league. If these participating leagues/teams are organized by age instead of grade, the league/team players must be 8U (age 8 and under).

USSSA’s Official Fastpitch Playing Rules and By-Laws, 15th Edition, are the Official Rules of Play (available at http://usssa.com/docs/2020/FPRB_Online_revised_011620.pdf unless otherwise stated in these **2026 A League Supplementary Rules and the WPD Youth Baseball / Softball “Policies and Procedures”**).

2026 SUPPLEMENTARY RULES

1. LEAGUE-SPECIFIC GENERAL RULES

- A. During the “Coach Pitch” segment (games 1-6) of the season an Umpire will not be scheduled. An Umpire will be scheduled during the “Player Pitch” segment (games 7-12) of the season. If an Umpire is not present, the team Managers will agree on a suitable volunteer umpire(s) either from the Coaching staff or from the many involved parents attending the game.
- B. Bases will be **60** feet apart. The pitching rubber will be **30** feet from home plate, measured from the rear point of home plate to the front edge of the pitching rubber (see diagram on page 5).
- C. Game duration will be 5 innings except as follows:
 1. Monday-Thursday games: A new inning may not start after 7:30 p.m.
 2. All games, including weekend games: A new inning may not start any later than 90 minutes after the scheduled start time of the game.

NOTE: *A new inning begins immediately after the last out of the preceding inning.*

3. A game is official if the home team is in the lead at the end of 3½ innings. If play is stopped before the game is official, the game is suspended and will be played from the point where play was stopped at another date and time scheduled in cooperation with the League Vice President.

- D. Bad weather or field condition may result in the postponement or cancellation of a game. Prior to the scheduled game start time, if no league official or umpire is present, the Home Team Manager will make the final decision to play, postpone or cancel the game due to field condition or weather. **See the Wheaton Park District's "Storm Policy" in the *Wheaton Park District Youth Baseball/Softball Policies and Procedures* and "Game Cancellation Procedure" in your *Managers Packet*.**
- E. Free substitution is permitted on defense, but such substitution will take place only between innings. During an inning a player cannot be brought off the bench to play except if an injury occurs.
- F. All attending players will play defense the maximum number of innings possible given the number of players present. This means that no player will sit out 2 innings unless all players have sat out 1 inning, and no player will sit 3 innings unless all players have sat out 2. In addition, a player will not sit out 2 consecutive innings.
- G. Every player must play at least two innings in a position other than the three outfield positions, during a complete game. Failure to comply will result in Board action.
- INTENT:** *It is mandatory that Managers rotate all defensive players.*
- H. Managers and coaches will not question judgment calls made by the umpire, such as fair or foul, safe or out, etc. Managers may approach the umpire if an interpretation of the rules is in question. The manager should ask for a "time-out" after the play is completed. Both managers, and only the managers, will be present during the conference. The discussion will be conducted in a calm and respectful manner. The decision of the umpire is final.
- I. There will be no standings kept for this league.

2. LEAGUE-SPECIFIC OFFENSE INFORMATION

- A. Official scores are not maintained; however, teams will be limited to 5 runs per inning.
- B. Base stealing is not allowed. Base runners must be in contact with the base when the ball is hit. If a runner leaves a base too soon, the ball will be called dead, a "no pitch" will be declared, and the runner will be called out. All other runners will return to the base they were at when the infraction occurred.
- C. ***All base runners must attempt to avoid a collision with a fielder in possession of the ball, catching a thrown ball, or about to field a batted ball.*** Any runner who remains on her feet and crashes into a fielder making the play in these three situations, whether intentional or not, will be called out for interference. Furthermore, if the act is determined to be flagrant or malicious, the offender will be restricted to the bench for the duration of the game. Runners have three options to avoid a collision: slide into the base they are *going to*, *step around a fielder*, or *pull up and allow themselves to be tagged*.

NOTE: *A collision that occurs when an errant throw draws a defensive player into the path of the runner is considered to be incidental contact. It is not interference, and no penalty will be imposed to either the defensive or offensive player.*

Conversely, a fielder may not impede the progress of a runner who is legally running bases while not in possession of the ball, not about to field a batted ball or not about to receive a thrown ball. Obstruction will be called in these situations, and the appropriate ruling will be made.

- D. Bunting **will not** be allowed. A batter must take a regular full swing at the ball. The batter will be called out if she intentionally bunts the ball. All other runners will return to the base they were at when the infraction occurred.
- E. The infield fly rule **will not** apply.
- F. The dropped third strike rule **will not** apply.
- G. There will be no on deck circle on the playing field.
- H. There will be no slaughter rule.
- I. If the player who will catch for the next ½ inning is on base and there are 2 outs, a courtesy runner shall be used to replace the player. The catcher should be ready by the third out (unless they were the last batter).

3. LEAGUE-SPECIFIC DEFENSE RULES

- A. A team may play a maximum of 10 players and a minimum of 8 players. All defensive players must play regular softball positions. The 10th player must play as a fourth outfielder. All four outfielders must start each pitch in the outfield grass. No player, except the pitcher and the catcher, will be closer than 45 feet to the batter when the ball is hit, and the pitcher must stand next to the coach who is pitching and be no closer than 33 feet from the plate.
- B. On a Ball Field composed of dirt and grass, the infield area is defined as the dirt part of the field. The outfield is defined as the grass behind the dirt. On an all-grass or all-dirt field, the outfield is defined as the area beginning 10 feet beyond the 1st & 2nd, and the 2nd & 3rd baselines.
- C. Attempting to throw the runner out without fear of potential failure is important to the development of the defensive player. Therefore, the following rules apply to determine what base a runner is entitled to as a result of a hit fair ball:
 - 1. When a hit fair ball is initially retrieved inside the base path, the runners may advance only to the base they were going to at the time of retrieval by the fielder regardless of whether the retrieved ball is held or thrown. If the ball is not retrieved (e.g., hit into the outfield), runners may advance no more than 2 bases from their original position, but if the ball is retrieved in the outfield area, the runner(s) may advance only to the bases they are going to at the time the ball is returned to the possession of an infielder.
 - 2. Possession is defined as having the ball in one's hand or glove.
- D. If a foul fly ball is caught, the batter is out, and no runner may advance. If a pop-up is caught in the infield, the batter is out, and no runner may advance. If a fly ball is caught in the outfield, the batter is out, and runners may advance at their own risk after they have tagged up.

NOTE: *In regard to the previous rules (C&D), it is important to note that runners are eligible to be thrown out even if they are not entitled to advance. If a player has advanced safely to a base beyond which she is entitled to, she will be awarded a safe return to the proper base when the play has been completed and the ball is dead.*

- E. During the first half of the season (first seven games), the coach or manager will pitch all innings of the game. The coach must pitch from the pitching rubber. Each batter will receive a maximum of 7 pitches from the Coach Pitcher unless the 7th pitch is fouled as explained below:

NOTE: *A batter may strike out on 3 strikes (swinging or called) unless the ball is fouled on the 3rd strike. On the 7th pitch (regardless of its quality), the batter will be called out if she does not hit a fair or foul ball. If the 7th pitch is fouled, the batter will continue to bat until she misses the ball, does not swing or hits a fair ball.*

- F. Rostered players will pitch during the “Player Pitch” segment (games 8-14) of the season. **Each pitcher is limited to two innings per game** regardless of the game length, and the innings need not be consecutive.

1. There are no “walks”.
2. The Coach will come in to pitch if any of the following scenarios occur:
 - a) The pitcher has thrown four (4) called “balls”.
 - b) The pitcher has thrown six (6) pitches and has not retired the batter.
 - c) A pitched ball hits the batter.

The strike count remains the same, the ball count is “0” and the Umpire will not continue calling balls and strikes.

3. The batter now has three options:
 - a) Hit a fair ball.
 - b) Strike out swinging.
 - c) Is “out” after the Coach throws four (4) pitches.

If the batter fouls off the fourth or last pitch, the batter will get another pitch.

4. The player pitcher must remain on the field positioned next to the pitching rubber and Coach Pitcher to field hit balls.
- G. A pitcher who hits three batters with pitched balls in the same inning must be removed from pitching for the remainder of the inning. She may return to pitch in subsequent innings as long as she is within the 2-inning limit described in 3. F.
- H. The defensive team may have 2 coaches in the outfield. The coach may offer brief instruction to players but may not interfere with the progress of the game.



Youth Baseball / Softball Board of Control

FAST PITCH SOFTBALL

A-LEAGUE (2nd Grade 8U)

Field Dimensions, Marking Lines and Distances

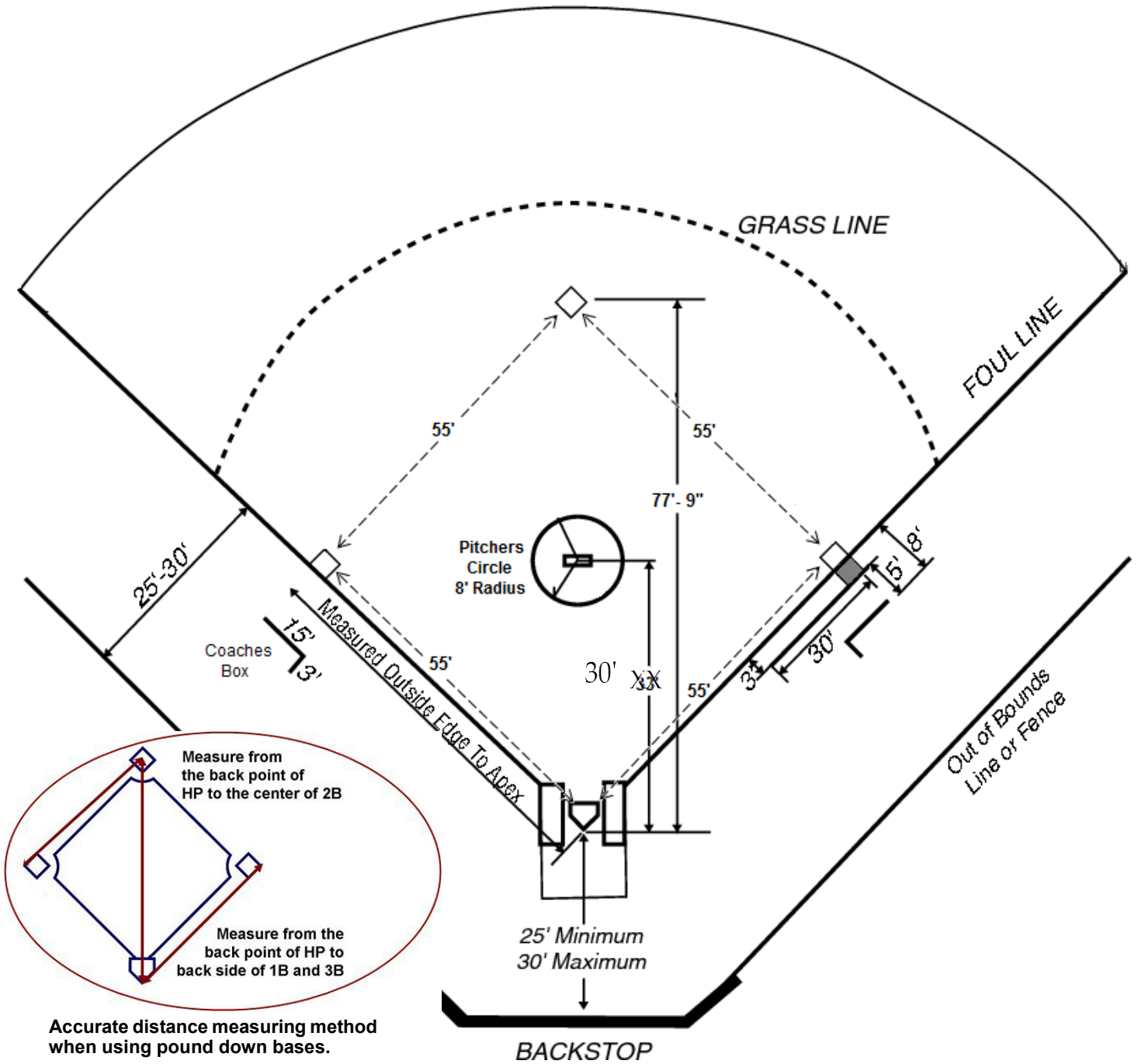

Accurate distance measuring method when using pound down bases.



Wheaton Park District Youth Baseball / Softball Board of Control

FAST PITCH SOFTBALL

A-LEAGUE (2nd Grade 8U) Specific Field Area Detail

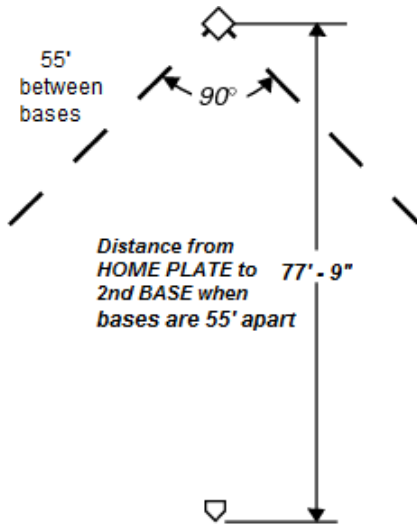

SECOND BASE AREA DETAIL

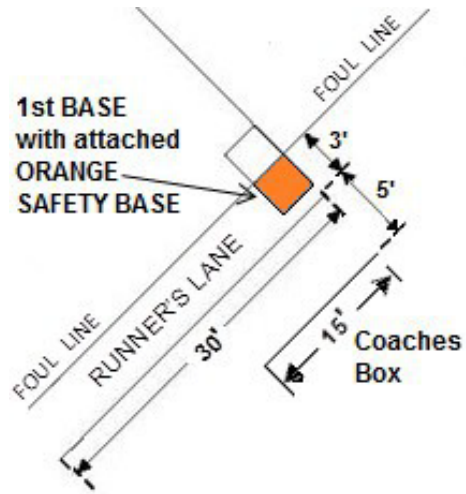

FIRST BASE AREA DETAIL

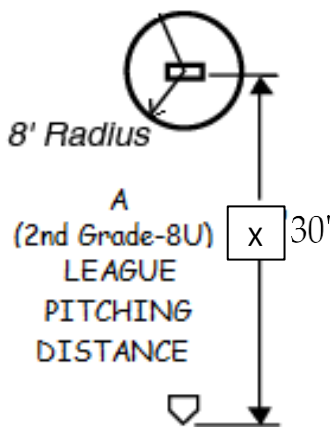

CIRCLE AREA DETAIL & PITCHING DISTANCE

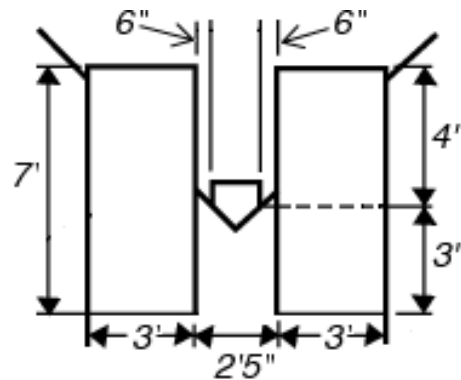

HOME PLATE & BATTERS BOX AREA DETAIL



Wheaton Park District Youth Baseball / Softball Board of Control

FAST PITCH SOFTBALL

Rules for Orange Safety Bases

Softball & Baseball Rules for Orange Safety Bases

In youth softball and baseball, one integral step toward safety is the use of the safety base at first. This innovation leads to fewer collisions along the base line and less risk of injury. The first baseman makes the play by standing on the original base while the runner will run over the orange safety base.

Description

The safety base is built as two standard bases in one. A standard baseball or softball base measures 15 inches by 15 inches. A safety base measures 15 inches by 30 inches. Half the base is the standard white color and the other half is fluorescent orange.

Placement

The safety base is used only at first base and is placed directly on the first base foul line. The white portion of the safety base is placed inside of the foul line - in fair territory, the orange half is placed in foul territory.

Rules

The safety base is designed to prevent collisions and other contact incidents at first base. The first baseman and other defensive players are only allowed to touch the white portion of the safety base during play. If a defensive player's foot touches the orange portion of the base, the umpire may call interference and award the runner a free base. This is an umpire's judgment call.

The orange base can be used by the fielder if the throw is coming from foul territory. In this case the runner would use the white base.

On offense, the batter runner must use the orange portion of the base during infield or close plays. Because a batter runner is allowed to run through first base, he/she must run straight through the orange half, remaining in foul territory. If he/she touches the white half on a play at first, the defensive team may appeal the play. If the umpire noticed the runner's foot placement, he/she will be called out. If there is no play to be made at first base, such as on a hit that will result in a double or better, the batter runner may touch the white half of the base while making the turn toward second. Batted balls that hit the white portion of the base are fair, while balls that hit the orange half are foul.

Summary

The use of the safety base not only limits potential dangerous collisions at first but also incidences of ankle injuries caused by one player stepping on another's ankle as they both stretch for the same base. When the first baseman has his/her foot on the white, and the runner sprints over the base, there's a chance of the runner rolling his/her ankle by stepping on the first baseman's foot.